



Product Summary

$V_{(BR)DSS}$	$R_{DS(on)TYP}$	I_D
200V	7.4m Ω @10V	130A

Feature

- Split Gate Trench Technology
- Low $R_{DS(ON)}$
- Low Gate Charge
- Low Gate Resistance
- 100% UIS Tested

Application

- Load Switching
- Motor Driving
- Power Management
- Current Switching

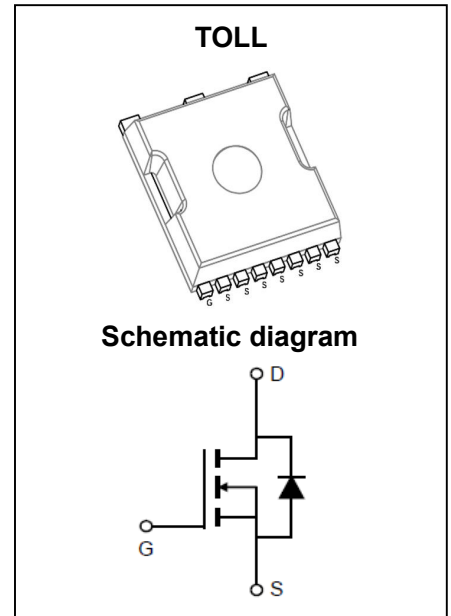

Package Marking and Ordering Information

Part Number	Package	Marking	Packing	Reel Size	Tape Width	Qty
GPT085N20NTP	TOLL	T085N20N	Reel & Tape	330mm	24mm	2000pcs

ABSOLUTE MAXIMUM RATINGS ($T_A = 25^\circ\text{C}$ unless otherwise noted)

Parameter	Symbol	Value	Unit
Drain - Source Voltage	V_{DS}	200	V
Gate - Source Voltage	V_{GS}	± 20	V
Continuous Drain Current ¹	$T_C = 25^\circ\text{C}$	I_D	130 A
	$T_C = 100^\circ\text{C}$	I_D	75 A
Pulsed Drain Current ²	I_{DM}	520	A
Single Pulsed Avalanche Current ³	I_{AS}	44	A
Single Pulsed Avalanche Energy ³	E_{AS}	484	mJ
Power Dissipation ⁵	$T_C = 25^\circ\text{C}$	P_D	375 W
Thermal Resistance from Junction to Ambient ⁶	$R_{\theta JA}$	45	$^\circ\text{C}/\text{W}$
Thermal Resistance from Junction to Case	$R_{\theta JC}$	0.4	$^\circ\text{C}/\text{W}$
Junction Temperature	T_J	150	$^\circ\text{C}$
Storage Temperature	T_{STG}	-55~ +150	$^\circ\text{C}$

MOSFET ELECTRICAL CHARACTERISTICS (T_A = 25°C unless otherwise noted)

Parameter	Symbol	Test Condition	Min	Type	Max	Unit
Off Characteristics						
Drain - Source Breakdown Voltage	V _{(BR)DSS}	V _{GS} = 0V, I _D = 250μA	200			V
Zero Gate Voltage Drain Current	I _{DSS}	V _{DS} = 200V, V _{GS} = 0V			1	μA
Gate - Body Leakage Current	I _{GSS}	V _{GS} = ±20V, V _{DS} = 0V			±100	nA
On Characteristics⁴						
Gate Threshold Voltage	V _{GS(th)}	V _{DS} = V _{GS} , I _D = 250μA	2	3.1	4	V
Drain-source On-resistance	R _{DS(on)}	V _{GS} = 10V, I _D = 20A		7.4	9.6	mΩ
Dynamic Characteristics						
Input Capacitance	C _{iss}	V _{DS} = 100V, V _{GS} = 0V, f = 1MHz		3521		pF
Output Capacitance	C _{oss}			440		
Reverse Transfer Capacitance	C _{rss}			45		
Gate Resistance	R _g	V _{DS} = 0V, V _{GS} = 0V, f = 1MHz		3.4		Ω
Switching Characteristics						
Total Gate Charge	Q _g	V _{DS} = 100V, V _{GS} = 10V, I _D = 20A		51		nC
Gate-source Charge	Q _{gs}			32		
Gate-drain Charge	Q _{gd}			19		
Turn-on Delay Time	t _{d(on)}	V _{DD} = 100V, V _{GS} = 10V, R _L = 5Ω, R _G = 6Ω		19		ns
Turn-on Rise Time	t _r			28		
Turn-off Delay Time	t _{d(off)}			37		
Turn-off Fall Time	t _f			21		
Source - Drain Diode Characteristics						
Diode Forward Voltage ⁴	V _{SD}	V _{GS} = 0V, I _S = 20A			1.2	V

Notes :

- 1.The maximum current rating is limited by package.And device mounted on a large heatsink
- 2.Pulse Test : Pulse Width ≤ 10μs, duty cycle ≤ 1%.
- 3.EAS condition: V_{DD} = 100V, V_{GS} = 10V, L = 0.5mH, R_G = 25Ω Starting T_J = 25°C.
- 4.Pulse Test : Pulse Width ≤ 300μs, duty cycle ≤ 2%.
- 5.The power dissipation P_D is limited by T_{J(MAX)} = 150°C.And device mounted on a large heatsink
- 6.Device mounted on 1in² FR-4 board with 2oz. Copper, in a still air environment with T_A =25°C.

TOLL Package Information

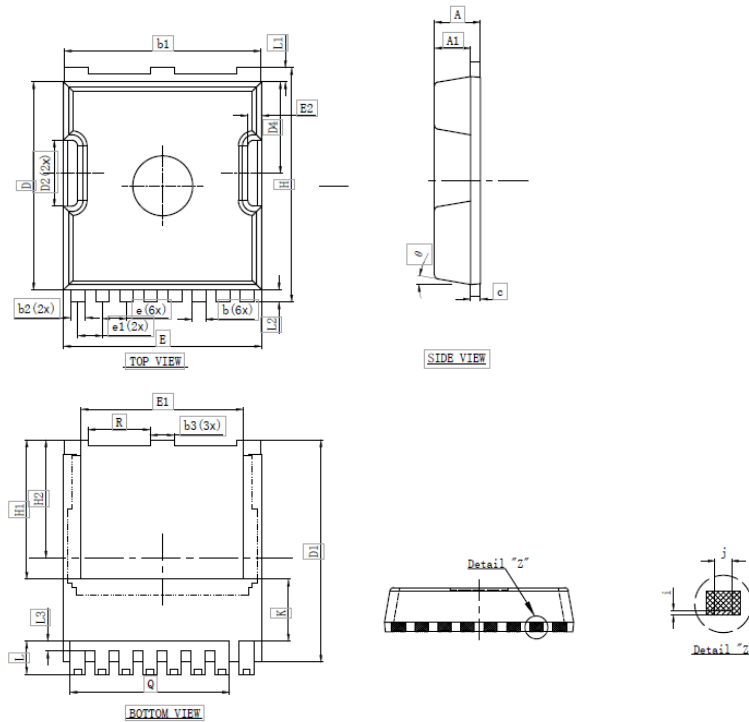

SYMBOL	MILLIMETER		Dimensions In Inches	
	MIN.	MAX.	Min.	Max.
A	2.200	2.400	0.087	0.094
A1	1.700	1.900	0.067	0.075
b	0.600	0.800	0.024	0.031
b1	9.700	9.900	0.382	0.390
b2	0.650	0.850	0.026	0.033
b3	1.100	1.300	0.043	0.051
c	0.400	0.600	0.016	0.024
D	10.300	10.500	0.406	0.413
D1	11.000	11.200	0.433	0.441
D2	3.200	3.400	0.126	0.134
D4	4.470	4.670	0.176	0.184
E	9.800	10.000	0.386	0.394
E1	8.000	8.200	0.315	0.323
E2	0.500	0.700	0.020	0.028
e	1.200 BSC		0.047BSC	
e1	1.225 BSC		0.048BSC	
H	11.600	11.800	0.457	0.465
H1	6.950 BSC		0.247BSC	
H2	5.900 BSC		0.232BSC	
i	0.100 REF		0.004REF	
j	0.350 REF		0.014REF	
K	3.100 REF		0.122REF	
L	1.550	1.750	0.061	0.069
L1	0.600	0.800	0.024	0.031
L2	0.500	0.700	0.020	0.028
L3	0.400	0.600	0.016	0.024
Q	7.950 REF		0.313REF	
R	3.000	3.200	0.118	0.126
θ	10°			

Attention:

- GreenPower Electronics reserves the right to improve product design function and reliability without notice.
- Any and all semiconductor products have certain probability to fail or malfunction, which may result in personal injury, death or property damage. Customer are solely responsible for providing adequate safe measures when design their systems.
- GreenPower Electronics products belong to consumer electronics or other civilian electronic products.